

Sand Scales

Manufacturers Information | PN447



Material Specifications

Frames	Powder-coated galvanised steel (option - stainless steel)
Discs	HDPE
Fixings	Stainless Steel

Equipment Specifications

Free Height of Fall	Not required
Fall Zone Size	Not required
Activity Space Recomm.	3125mm x 2200mm
Highest Point	1000mm

Other Required Information

Spare Parts	Available to order
Largest Part	Item: 1200 x 200 x 1100mm
Heaviest Part	21 - 40kg Two Person Lift

Standards

AS 4685 2021 Series

Applications

Age Group	1 to 5 years
Supervision Level	Young children should be supervised and inappropriate activities discouraged
Playspaces	Public parks, schools, early childhood centres commercial play areas
Environment	Shade preferred for user comfort and protection. Salt air environments may reduce life of steel.
Vandalism Resistance	Low susceptibility

Product Dimensions

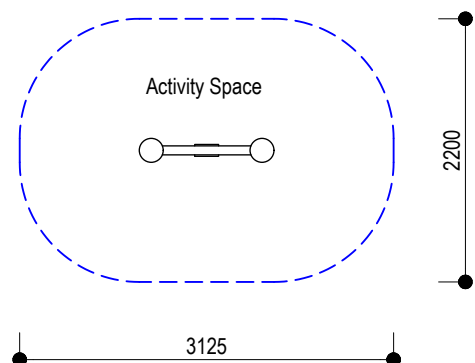
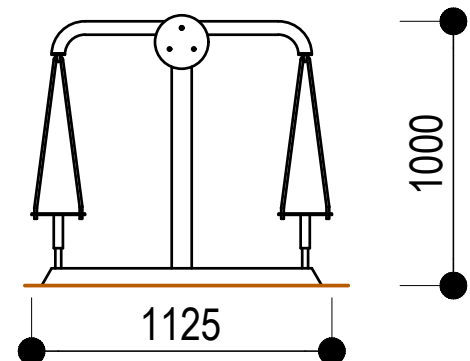

Sand Scales

Manufacturers Information | PN447

Installation

Footing quantities and depths

From ground level

Item	Qty	Hole Diameter	Hole Depth
Posts	2	300mm	600mm

Note:

This product is designed for 300mm softfall. Check the proposed on site softfall depth. If it is not 300mm, please adjust depths of post holes accordingly, to achieve correct overall subsurface depth. This will maintain correct height of equipment above undersurface level.

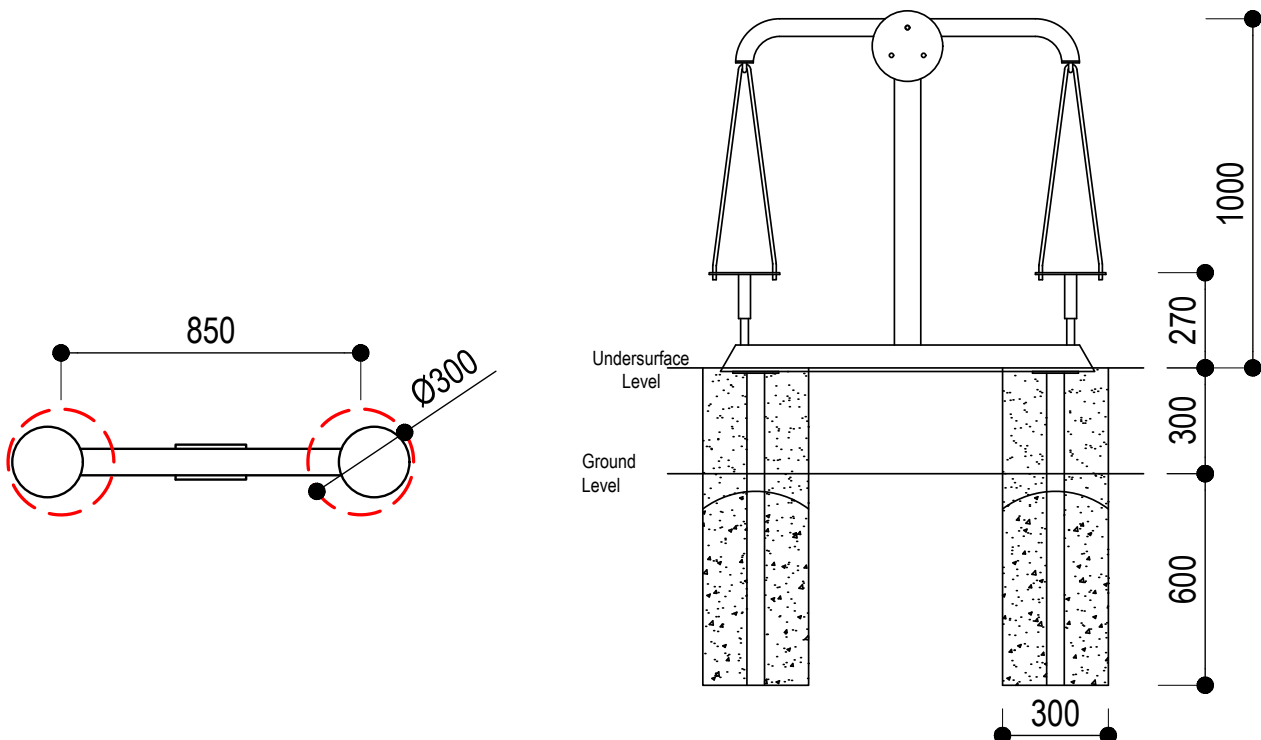

Inspection Notes

All inspections and maintenance to be carried out by competent people with the appropriate knowledge, experience and authority.

Inspection Frequencies

These are a guide only - local risk factors such as heavy usage, nearness to coast, and vandalism patterns need to be taken into account.

Routine Visual Inspection - Daily

Check for breakages, loose fittings and debris. Where safety issues are identified, quarantine until repaired.

Operational Inspection - Quarterly

RVI plus:-
Check for wear in moving parts e.g. bearings, chains and links.
Check security of fixings.

Comprehensive Inspection - Annually

OI plus :-
Check for structural rigidity and degradation e.g. corrosion, decay etc.
Where possible, remove undersurfacing to examine condition of supports and footings.

Maintenance - Annual

In areas of high exposure to sun, wind and rain more frequent treatments may be necessary.

Note: Ensure all replacement parts conform with manufacturers original specifications

Note: In heavy use environment, more frequent inspection regime recommended

Note: Quarantine equipment during installation, inspection & maintenance